



Data Sheet for : **AQUARIUS 700D** Trailer Mounted Concrete Pump



TRAILER MOUNTED LINE PUMPS - 700 SERIES



▶ Salient Features:

- ▶ New futuristic look with latest design
- ▶ Completely redesigned with many operation friendly features
- ▶ Substantial noise reduction
- ▶ Maximum vertical/horizontal pumping distance in this class
- ▶ Most fuel-efficient series
- ▶ Very reliable equipment with long routine maintenance intervals
- ▶ Safe water-cleaning system
- ▶ Compact design and least towing length
- ▶ Very effective reverse pumping
- ▶ Infinitely variable concrete output, from minimum to maximum
- ▶ Centralized greasing points
- ▶ Uninterrupted operations even if electrical system malfunctions
- ▶ Innovative flap straight design with cleaning socket
- ▶ Standardized core pump, reducing spares inventory costs

▶ Added Features:

- ▶ Higher Capacity jack
- ▶ Foot rest for hopper
- ▶ Gas springs and locks for canopy
- ▶ Shifting cylinder cover for better safety
- ▶ Grill provided for engine cover
- ▶ Built-in toolbox
- ▶ Efficient splash guard design
- ▶ Mudguard on tyre
- ▶ Engine & Pump hour meters
- ▶ Remote control



Worldwide Preferred
'S' Valve Technology

► Technical Specifications:

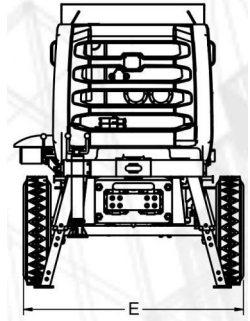
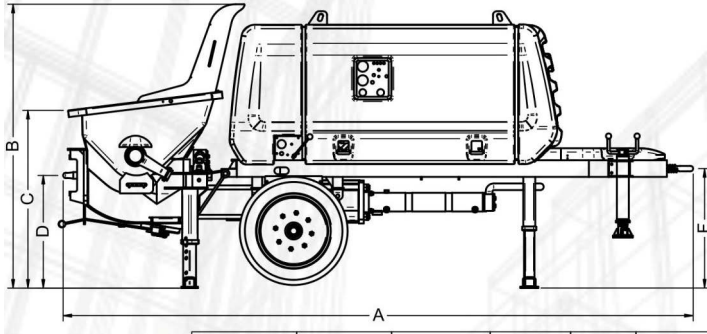

MODEL	A	B	C	D	L	F
703D	4730	2125	1330	845	1650	890

Model Specifications

	Unit	703 D	703 E
Prime Mover	kW	34.6	37
Theoretical Output	m ³ /hr	30	23
Del. Cylinder Diameter	mm	200	200
Del. Cylinder Stroke	mm	700	700
No. of Strokes	per min	22.5	17
Hydraulic Transmission	--	1:3.3	1:3.3
Concrete Pressure	bar	76	76
Concrete Hopper Capacity	l	500	500
Delivery Distance**	Horizontal	m	320
	Vertical	m	80

**Distances to be read as either horizontal or vertical. The concrete should be pumpable & follows DIN 1045 standard.



Cylinder Diameter Comparison

AQUARIUS

Concrete Pumps

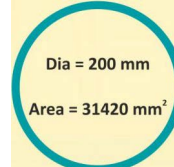

Other

Concrete Pumps

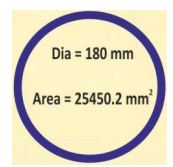

Aquarius Pump Cylinders have larger area than others by 23.5%

Largest & Longest 'S' Valve

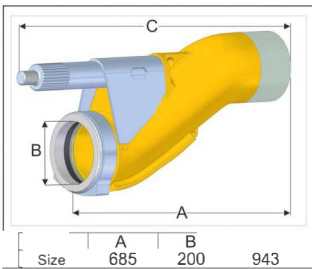

Variable Output Regulator

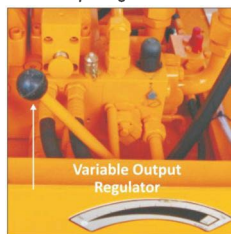

Performance of equipment is based on standard working conditions. Design / Specifications can be changed without prior notice.



East West Engineering Service Pvt Ltd.
12-01 East Tower, 1World Trade Center
Colombo 00100, Sri Lanka

For Further information please contact:

SPECIAL PROJECTS MANAGING DIRECTOR
Vijitha Wijesuriya
Mobile : +94 77 7322500
Email : vijitha@eastwest.lk



EAST WEST READY MIX

Suppliers of high quality Ready Mix concrete

ADMINISTRATION & ACCOUNTS
Nishantha Sooriyaarachchi
Mobile : +94 777 880 297
Email: Nishantha@eastwest.lk